

RESEARCH ARTICLE

Available Online at <http://www.aerjournal.info>

Sensitivity of the Native *Chironomus* Species in Monitoring of Riverine Ecosystems in the Catchments of Lake Victoria Drainage Basin, Kenya

K. Nyakeya^{1*}, P. O. Raburu, F. O. Masese, J. Tsuma, J. M. Nyamora, E. W. Magongu, D. D. Kemunto, R. N. Ondiba and M. Jepkosgei
Kenya Marine and Fisheries Research Institute, P.O. Box 31, Kampi ya Samaki, Baringo, Kenya; kobinginyakeya@gmail.com

Abstract

Globally, anthropogenic activities continues to pose wide spread pollution into the aquatic ecosystems such as rivers. This study set out to assess the sensitivity of Chironomus species to justify their use in monitoring of riverine ecosystems in the Lake Victoria Basin, Kenya. Chironomid midges were sampled from upstream and downstream of paper mill factory in the River Nzoia and sugar cane factory in the River Mbogo for toxicity tests in the laboratory. In the laboratory, midges were exposed to different dilutions of paper-mill factory effluents and sugar cane factory effluents. They were observed for mortality after every one hour for 24 hours and in case of any mortality, the dead midge was removed and counted. Sensitivity was then calculated as a percentage of the total number that died over the total midges exposed for each test. Results for all the tests were evaluated for variability among treatment effects and control using analysis of variance (ANOVA). There were significant effects ($p < 0.05$) of effluents on sensitivity. The study, therefore, concluded that Chironomus species are sensitive to pollutants emanating from sugar cane processing and paper mill effluents, hence can be used as test organism in monitoring the health of riverine ecosystems in LVB. It was recommended that on-field toxicity tests for the Chironomus species be done.

Key Words: Bioindicators, Chironomus Species, Effluents, Sensitivity and Ecotoxicology

Introduction

River pollution is common in the present world and has caused severe environmental consequence (Castillo, Vila, & Neild, 2000). In Kenya, most important contamination sources are domestic and industrial wastewaters, urban and agricultural runoff (Osano, Nzyuko, & Admiraal, 2003; Raburu, Masese, & Mulanda, 2009a). As a management strategy, many regulatory efforts have been geared towards chemical analysis to identify the level of various pollutants in streams and rivers (Getenga, Keng'ara & Wandiga, 2004; Mwamburi, 2003) and establishing discharge standard that maintain established threshold levels (EMCA, 2006). Chemical methodologies, (Kohler, Belkin, & Schmid,

2000) are essential for regulatory purposes but mostly lack the ability to assess toxicity, bioavailability and potential antagonistic/synergistic effects of pollutants on aquatic ecosystems (Vangheluwe, Janssen & Van Sprang, 1999). The limitations of chemical analysis are particularly apparent when the chemical nature of pollutants is unknown, in which case an extensive array of instrumentation needs to be used, often in a time consuming and costly manner (Liess, *et al.*, 1999).

Because of the above mentioned shortcomings with chemical analyses, recent advances in Kenya to assess and monitor pollution on rivers have focused on the use of biological criteria (Masese, Muchiri, & Raburu, 2009b, Raburu &

Masese, 2010, Raburu *et al.*, 2009a). However, a prerequisite for the development of useful biological indicator systems is that different species should be ranked in the order of their sensitivity to the stress parameter of interest (Wogram & Liess, 2001). In Kenya, there is scarce information about macroinvertebrate sensitivities to contaminants emanating from different sources. Such sensitivities can be obtained using different contaminants, e.g., metals in effluents, inorganic salts and pesticides. Hence, the aim of this study was to determine the sensitivity of *Chironomus* species to industrial effluents from pulp, paper mill and sugarcane processing.

Materials and Methods

Field Sampling

Chironomus species for the tests in the laboratory were sampled on two locations in the Rivers Nzoia and Mbogo, a tributary joining R. Nyando within the LVB, i.e. polluted site (C for R. Nzoia and D for R. Mbogo) and pristine site (R for R. Nzoia and S for R. Mbogo) (reference site). This was important because we hypothesized that organisms taken upstream with least levels of human perturbations could respond differently to effluents as compared to those taken downstream where anthropogenic activities are more intense. Effluent contamination in R. Nzoia comes from

Webuye kraft paper factory whereas R. Mbogo receives effluent contaminants from Chemelil Sugar factory. Reference sites were located upstream in the forest from the two factories whereas the polluted sites were 2 km downstream from the point of the factories. The larval sampling occurred in sediment banks using a scope net.

Collection of Effluents and Preparation

Liquid effluent samples from the two factories were taken at a point by immersing a 20 litre empty drum into the treatment lagoon between the final treatment and the discharge outfall. Samples were transported to the laboratory and stored at 0-4°C to inhibit microbial degradation, chemical transformations, and loss of highly volatile toxic substances. They were used within the 36-h period (USEPA, 2002).

Laboratory Acclimatization

Larvae were transported to the laboratory and acclimatized following established protocols (Figure 1) (Fonseca & Rocha, 2004; Santos, Vicensotti, & Monteiro, 2007). Dechlorinated water was used for toxicity tests. The midges were fed on chick mash and a 12:12, light: dark photoperiod regime was maintained. The water temperature of the aquaria was maintained at 25±1°C. All the tests were done under static non-renewal acute toxicity test.

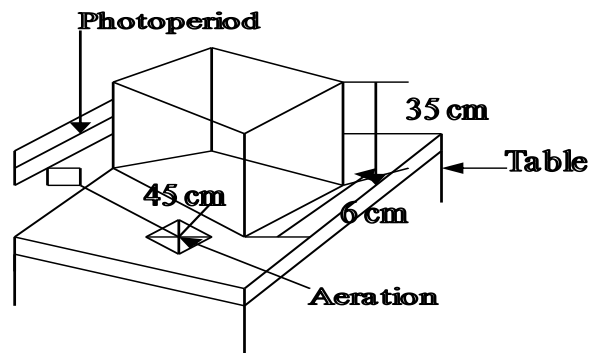

Figure 1. General View of the Aquarium that was Used for Maintaining *Chironomus* Species in the Laboratory

Identification of the Chironomids

In order to ascertain that the organisms sampled belonged to the *Chironomus* species, the midges were identified to the lowest level possible using identification keys (Epler, 1995). Larval specimens stored

in 70% ethanol were observed under a dissecting microscope to ascertain their physical features before the head capsule was removed for further investigations (Plate 1).



X5 magnification

Plate 1. Fourth Instar Chironomid Larvae Used in this Study (Photo by Kobingi Nyakeya, 7th May, 2014)

The head capsule of each individual specimen was carefully removed while observed under a dissecting microscope (GallenKamp) using a needle and a sharp thin metal plate. The head capsule was then put in a 10% potassium hydroxide (KOH) for 6-24 hours to remove the soft obscuring tissues. It was mounted on the slide using Euparal mountant ventrally. The mentum teeth were examined and counted as well as the antennae segments. This is because such

features alone can differentiate one group from another.

The wings of the reared Chironomid adults were also removed while observed under the dissecting microscope and mounted on the slides using Euparal mountant and observed under the compound microscope (Plate 2) with different ranges of magnification (x5 – x40) in order to be used in the identification of the test organisms.

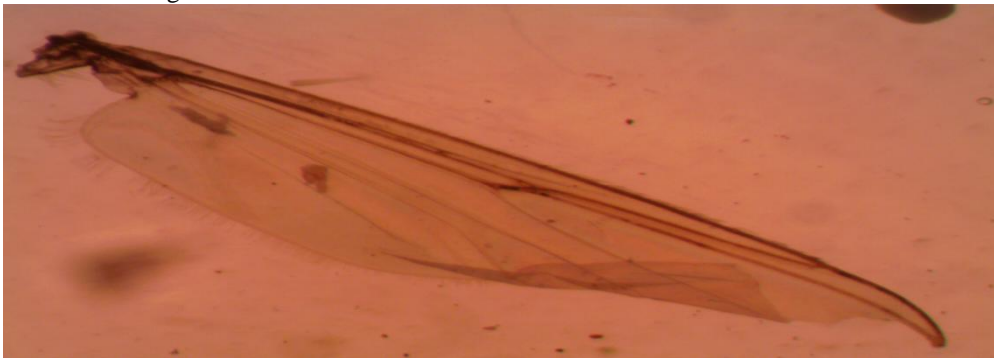

X40 magnification

Plate 2. A Wing of an Adult *Chironomus* Species (Photo by Kobingi Nyakeya, 7th May, 2014)

Bioassays/ Bio Assessment

Experimental Design

Five industrial effluent samples plus control for each test with four replicates were used for the sensitivity test of the *Chironomus* midges. Ten live midges were exposed to each industrial effluent sample concentration by picking each by the use of a pipette (Jensen, 1972). Then serial dilutions of the effluents using dechlorinated tap water for each test was done with a factor of 0.5 (USEPA, 2002). Ten midges in all the experiments were added to 0.5 l beakers, containing the appropriate serial effluent dilutions, with approximately 1cm layer of sterilized sand and 1.0 ml of food suspension. A temperature of $25\pm 1^{\circ}\text{C}$ and a 12:12, light: dark regime was maintained. The experiment ran for 24 hours. The experimental set up was inspected after every one hour to check for any mortalities until the 24th hour. In case of any mortality, the dead chironomid larvae were removed from the beaker and the total number of dead ones noted.

Sensitivity: To test for sensitivity of the *Chironomus* species once exposed to paper pulp mill and sugarcane effluents, the proportion data was derived using the following formula:

$$\text{Sensitivity} = \frac{\text{Number of true positives}}{(\text{Number of true positives}) + (\text{Number of false negatives})}$$

Where number of true positives refers to those midges that actually died as a result of toxicity emanating from the paper pulp mill and sugarcane effluents, and number of false negatives are midges that did not die after the 24 hour exposure.

Data Analysis

Results for the effluent toxicity test on sensitivity of the *Chironomus* species were presented as means (\pm Standard Error of Mean, SEM). Data for the tests was first transformed by the Probit transformation to stabilize the variance and satisfy the normality requirement before analysis. Two way ANOVA for the tests of the *Chironomus* species midges was run with the station. Concentration was the main factors with the station x concentration interaction effect and where there was no interaction, then 1-way ANOVA was run with the main individual factors only (i.e. effluent, station and concentration). *Post hoc* Tukey test was then performed to identify means of concentration of the different test parameters for the *Chironomus* midges differing from one another. One-Way ANOVA was used to determine significant difference between the control and the effluent concentrations. All analysis was done in Sigma Plot and the significant differences were inferred at $\alpha=0.05$ level.

Results

Species Identified in the Study

Four species were identified and classified in this study. They included *Chironomus decorus*, *Chironomus riparius*, *Chironomus stigmaterus* and *Goeldichironomus c.f. natans*.

Sensitivity

Chironomus species taken from station S of R. Mbogo which acted as the reference point in this river, recorded the highest percent sensitivity level ($64.0\pm 9\%$) as compared to those collected from the rest of the stations in the two rivers. This was followed by station R (reference point) of R. Nzoia ($54.0\pm 8\%$) as illustrated in Figure 2 below.

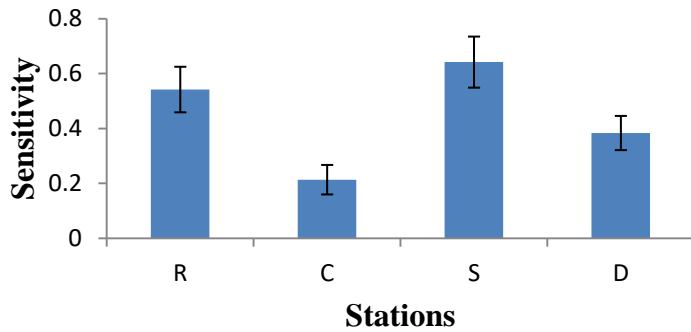

Figure 2. Mean (± SEM) Percentages of the Sensitivity (%) of the *Chironomus* Species from the Four Stations of rivers Nzoia and Mbogo

The least percent sensitivity (20.0±5%) was noted in station C of R. Nzoia in which the midges were exposed to paper and pulp effluent. Station D of R. Mbogo on the other hand recorded (38.0±6%) percent sensitivity. In terms of sensitivity effects, therefore, midges from upstream stations of both rivers died most once exposed to the effluents whereas those from downstream stations recorded least number of deaths. This implied that both effluents were most potent in killing midges taken from upstream stations of the two rivers while they were least efficacious to larvae sampled downstream. From the range of doses used. Therefore, the sensitivity effect

from exposure observation of the *chironomus* spp. was found to be station dependent ($p < 0.05$).

It was observed that *Chironomus* spp. became slowly inactive within 24 hours and began to fall towards the bottom of the glass beaker during the exposure at various exposure doses (Figure 3). The treated larvae showed curling up, anxiety and vigorous body movements. In each sensitivity observation time, the lowest dosage had the lowest sensitivity while the highest dosage had the highest sensitivity (Figure 3). Consequently, the sensitivity effect from exposure observation was found to be dosage dependent ($p < 0.05$).

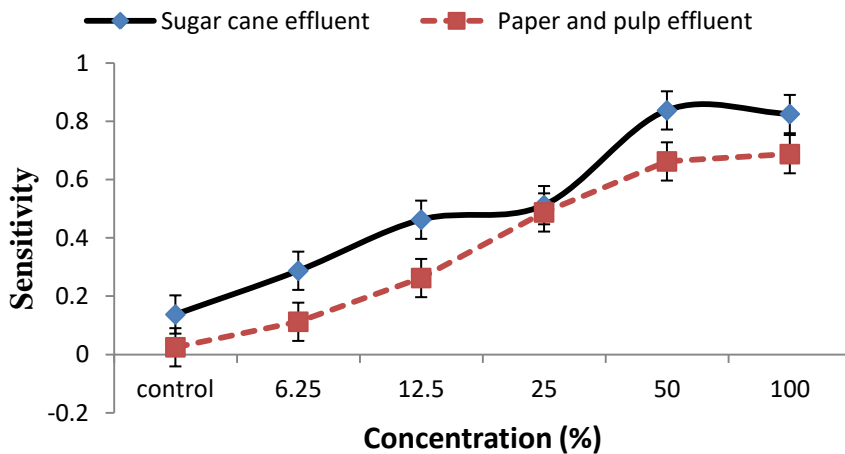

Figure 3. Mean (± SEM) Percentages of the Sensitivity of the *Chironomus* Species under Different Levels of Effluent Concentrations

Two-Way ANOVA (Table 1) showed that sensitivity of the *Chironomus* spp. that were sampled from the two rivers and exposed to both sugar cane; and paper and pulp effluents under different dilutions in the laboratory differed significantly between effluents (F=52.54, p=0.001); stations (F=111.474, p=0.001); concentrations (F=158.453, p=0.001) and among stations combined with concentrations (F=6.768, p=0.001). Analysis of the effluents combined with the concentrations did not have any effect on the sensitivity of the exposed midges.

Table 1. Summary of Two-Way ANOVA Showing Variation for Sensitivity, with Effluent, Station, Concentration, Effluent x Concentration and Station x Concentration *=p<0.05

| Source of Variation | DF | SS | MS | F | P |
|--------------------------|----|---------|---------|---------|---------|
| Sensitivity | | | | | |
| Effluent | 1 | 0.45375 | 0.45375 | 52.54 | <0.001* |
| Station | 3 | 2.648 | 0.883 | 111.474 | <0.001* |
| Concentration | 5 | 6.272 | 1.254 | 158.453 | <0.001* |
| Effluent x Concentration | 5 | 0.08 | 0.016 | 1.85 | 0.115 |
| Station x Concentration | 15 | 0.804 | 0.0536 | 6.768 | <0.001* |
| Residual | 66 | 0.57 | 0.00792 | | |
| Total | 95 | 10.293 | 0.108 | | |

*Denotes significant difference

Relationship among the Concentrations Chironomid midges in the control and all other effluent concentrations (F=21, p=0.001). *Post hoc* Tukey test for sensitivity showed a significant difference between the

Table 2. *Post hoc* Tukey Test among Means of Different Concentrations for Sensitivity, Specificity, LC50, Deformity and Emergence (p<0.05)

| Concentration (%) | Sensitivity |
|-------------------|-------------|
| 0 | 0.08±0.025a |
| 6.25 | 0.2±0.048b |
| 12.5 | 0.4±0.048c |
| 25 | 0.5±0.048d |
| 50 | 0.75±0.05e |
| 100 | 0.76±0.028e |

a,b,c,d,e shows an effect

Discussion

The results of this study revealed that chironomid midges sampled at upstream stations of R. Nzoia and R. Mbogo were more sensitive to sugarcane and paper pulp effluents in the laboratory as compared with those sampled from exposed sites downstream. This is most probably due to the fact that downstream stations receiving effluents from the factories may have contributed to adaptation changes in the parental chironomids that may have passed the environmental traits (non-genetic) to their off springs (Fernandez, et al., 2011; Bonduriansky, et al., 2011). It is also argued that adaptation of organisms in an environment is likely to play an important role in allowing populations to persist

through periods of rapid environmental change (Fernandez et al., 2011).

It is also argued that adaptation of organisms in an environment is likely to play an important role in allowing populations to persist through periods of rapid environmental change (Chevin, Lande, & Mace, 2010). Results from this study supports arguments advanced by other researchers that within-generation phenotypic plasticity, transgenerational effects of environment influenced by non-genetic mechanisms of inheritance could influence the rate and direction of adaptation (Bonduriansky, et al., 2011). This explains the reason why chironomid midges collected downstream effluent discharge sites survived more in the

laboratory tests as compared to those from upstream sites.

The environment from which an organism lives in may differ ecologically. The differences in sensitivity witnessed in the present study may have been elucidated as a result of midges sampled from varying ecological zones. Chironomids may have locally adapted populations due to varying behavioural patterns and spatially differing ecological characteristics (Groenendijk, 1999). Such an occurrence can be repeated in a predictable way making the *Chironomus* species thrive through adaptation and as a result parents could pass such adaptive traits to their off springs. Consequently, non-genetic inheritance can be advantageous as a form of adaptive transgenerational plasticity in a changing environment (Fernandez *et al.*, 2011): if environmental conditions fluctuate in a predictable manner, then parents will benefit by producing offsprings whose phenotypes are optimized for the anticipated conditions (Bonduriansky *et al.*, 2011).

Conclusions

From the results of this study, sensitivity of the *Chironomus* species exposed to the two effluents increased with an increase in the effluent concentration. Sensitivity also increased downstream in regard to the sampling stations of the Chironomid midges under study. It is also concluded that, *Chironomus* species are sensitive to pollutants emanating from sugarcane processing and paper mill effluents, hence can be used as test organism in monitoring the health of riverine ecosystems in LVB. Based on the findings of the study, the following were the recommendations:

There is need to carry out sensitivity studies at different prolonged intervals of time to determine whether there occurs any meaningful variation in sensitivity of *Chironomus* spp. when exposed to the two effluents.

Studies to be carried out in establishing whether *Chironomus* species at

contaminated sites have a tolerance that is genetically passed on or acquired.

References

- Bonduriansky, R., Crean, A. J. & Da, T. (2011). The implications of nongenetic inheritance for evolution in changing environments. *Evolutionary Applications*. Blackwell Publishing Ltd.
- Castillo, G. C., Vila, I. C., & Neild, E. (2000). Ecotoxicity assessment of metals and wastewater using multitrophic assays. *Environmental Toxicology* 15, 370-375.
- Chevin, L. M., Lande, R. & Mace, G. M. (2010). Adaptation, plasticity, and extinction in a changing environment: towards a predictive theory. *PLoS Biology* 8:e1000357.
- EMCA (2006). Environmental Management And Co-Ordination (Water Quality) Regulations, 2006. In, (Government of Kenya)
- Epler, J. H. (1995). Identification manual for the larval Chironomidae (Diptera) of Florida (Revised Edition), 320p.
- Epler, John H. "Identification manual for the larval Chironomidae (Diptera) of Florida." *Identification manual for the larval Chironomidae (Diptera) of Florida*. Revised Edition (1995
- Fernández-gonzález, M. A., González-barrientos, J. Carter, M. J. & Ramos-jiliberto, J. (2011). Parent-to-offspring transfer of sublethal effects of copper exposure: Metabolic rate and life-history traits of *Daphnia*. *Revista Chilena de Historia Natural*, 84: 195-201.
- Fonseca, A. L., & Rocha, O. (2004). Laboratory cultures of the native species *Chironomus xanthus* Rempel, 1939 (Diptera-Chironomidae). *Acta Limnol Bras* 16 153-161.
- Getenga, Z. M., Keng'ara, F. O., & Wandiga, S. O. (2004). Determination of organochlorine pesticide residues in soil and water from river Nyando drainage system within lake Victoria Basin, Kenya. *Bulletin Environmental Contamination and Toxicology* 72(2), 335-343.
- Groenendijk, D. (1999) Dynamics of metal adaptation in riverine chironomids, PhD, University of Amsterdam, Kruislaan, Amsterdam, Netherlands.

- Jensen, A. L. (1972). Standard error of LC50 and sample size in fish bioassays. *Water Research*. *Water Res 6 (1)*, 85-89.
- Kohler, S., Belkin, S., & Schmid, D. R. (2000). Reporter gene bioassays in environmental analysis. *Fresenius Journal of Analytical Chemistry* 366, 769-779.
- Liess, M., Schulz, R., Liess, M. H. D., Rother, B., & Kreuzig, R. (1999). Determination of insecticide contamination in agricultural headwater streams. *Water Research* 33, 239- 247.
- Masese, F. O., Muchiri, M., and Raburu, P. O. (2009b). Macroinvertebrate assemblages as biological indicators of water quality in the Moiben River, Kenya. *African Journal of Aquatic Science* 34, 15-26.
- Masese, F. O., Raburu, P. O., & Muchiri, M. (2009a). A preliminary benthic macroinvertebrates index of biotic integrity (B-IBI) for monitoring the Moiben River, Lake Victoria Basin, Kenya. *African Journal of Aquatic Science* 34 (1), 1-14.
- Mwamburi, J. (2003). Variations in trace elements in bottom sediments of major rivers in Lake Victoria's basin, Kenya. Lakes and Reservoirs: *Research and Management* 8(1), 5-13.
- Osano, O., Nzyuko, D., & Admiraal, W. (2003). The fate of chloroacetalinide herbicides and their degradation products in the Nzoia Basin, Kenya. *Ambio: A Journal of the Human Environment* 32(6), 424-427.
- Raburu, P. O., & Masese, F. O. (2010). Development of a Fish-Based Index of Biotic Integrity (FIBI) for monitoring riverine ecosystems in the Lake Victoria drainage basin, Kenya. In *River Research and Application*, (John Wiley and Sons Ltd.), p. 1428.
- Raburu, P. O., Masese, F. O., & Mulanda, C. A. (2009a). Macroinvertebrate Index of Biotic Integrity (M-IBI) for monitoring rivers in the upper catchment of Lake Victoria Basin, Kenya. *Aquatic Ecosystem Health and Management* 12 (2), 197-205.
- Santos, M. A. P. F., Vicensotti, J., & Monteiro, R. T. R. (2007). Sensitivity of four test organisms (chironomus xanthus, daphnia magna, hydra attenuata and pseudokirchneriella subcapitata) to NaCl: an Alternative Reference Toxicant. *Journal of the Brazilian Society of Ecotoxicology*. *J Braz Soc Ecotoxicol* 2(3), 229-236.
- USEPA (2002). Methods for measuring the acute toxicity of effluents to freshwater and marine organisms. In, (United States Environmental Protection Agency, Office of Water).
- Vangheluwe, M. L., Janssen, C. R., & Van Sprang, P. A. (1999). Selection of bioassays for sediment toxicity screening, In *New microbiotests for routine toxicity screening and biomonitoring* (pp. 449-458). Springer US (New York: Kluwer Academic).
- Wogram, J., & Liess, M. (2001). Rank Ordering of Macroinvertebrate Species Sensitivity to Toxic Compounds by Comparison with That of *Daphnia Magna*. *Bulletin of Environmental Contamination and Toxicology* 67, 360-367.